

**CCT-3300 series**  
**Conductivity (TDS) Controller**

**Operation Manual**

## Notes before Operation

### 1. Notice before operation:

(1) Carefully read the relevant parts of this manual before installation and operation to prevent wrong operation, measurement error and damage of instrument.

(2) Improper installation and unsuitable flow speed will cause big measurement error, so please read the installation passage in detail.

(3) This instrument is precise electrochemical measurement, and its installation and operation should be performed by technicians with relevant professional knowledge.

### 2. Maintenance items:

(1) The meter's quality guarantee is one year from the date of purchasing. During this period, if the meter has quality problems, manufacturer is responsible for maintenance work for free or changes it.

(2) Manufacturer offers the maintenance service for whole life of the sold meters.

(3) If the damage of the meter is caused by the following reasons, it is out of the maintenance service:

A、 The meter is burned or foundered caused by improper usage and maintenance.

B、 The meter is refitted or misused without permit.

C、 The meter is destroyed under the condition out of company's regulation.

D、 The relevant damage caused by choosing the wrong type.

E、 The cable damage and rupture caused by improper installation and usage.

F、 The incorrect measurement of the sensor caused by disconnecting or connecting wires personally.

G、 The inner broken wire caused by indiscreetly disassembling.

## Catalogue

I.	Product General Introduction.....	1
1.	1 Main technical index.....	1
1.	2 Applications .....	2
1.	3 Products classification .....	2
1.	4 Notices of product installation.....	2
1.	5 Main technical index.....	3
II.	Outline Dimension and Rear Terminals .....	4
2.	1 Outline dimension .....	4
2.	2 Rear terminals .....	4
2.	3 Wire connection .....	5
III.	Electrical Connection .....	6
3.	1 mA wire connection diagram.....	6
3.	2 Electrical connection .....	7
3.	3 High limit and window control.....	7
IV.	Introduction of Front Panel and Key Functions .....	8
4.	1 Front panel and main menu display.....	8
4.	2 Key board functions Introduction.....	9
V.	Introduction of Operation Menu .....	9
VI.	Introduction for Electrode Installation .....	10
6.	1 Selection for electrode constant .....	10
6.	2 Outline dimension of the electrode .....	10
6.	3 Installation method .....	11
6.	4 Installation and maintenance .....	12
VII.	Failure Judgment for Meter and Electrode.....	13
VIII.	Complete Set of Products .....	14
IX.	Ordering Directory .....	14



## **I. Product General Introduction**

CCT-3300 series conductivity (TDS) measurement controller is a high-technology innovative product. Product performance and function updated to a new level. It is a product with high performance and price ratio for inline water quality conductivity analysis.

### **1. 1 Main Technical Index**

- No adjustable component inside the instrument, totally programmed automatic calibration, higher reliability;
- Automatic measurement range shift, digital temperature compensation.
- Support conductivity cell constant ( $0.1 \text{ cm}^{-1}$ ,  $1.0 \text{ cm}^{-1}$ ,  $5.0 \text{ cm}^{-1}$ ,  $10.0 \text{ cm}^{-1}$ ), measurement range compatible with liquid from pure water to concentrated solution, named online conductivity superman.
- Conductivity (uS/cm) or TDS (ppm) engineering unit display can be chosen in operation.
- present water temperature ( $^{\circ}\text{C}$ ) / transmitting current (4~20mA) can be check onsite.
- Measurement and calibration program for calculation and measurement inspection organization.
- Isolated, transferable 4~20mA current output, two points transmitting range random setting within full scope. Support all the two wire PLC system under transmitter model.
- Conductivity high limit alarm, high limit value and backlash value random setting within full measurement scope.
- Patent short housing and fast installation method to save more space for the project,
- High illumination, pure white backlight LCD display in accordance with international trend.
- Industrial standard wire contact, EMC electromagnetic compatible design, platform design development, serial product classification.
- Meeting international electronic power supply regulation, AC ,DC current input which with non polarity wire connection,
- Our products with strict quality management , SMT (Surface Mounted Technology), AOI (automatic optical inspection (system), ICT ...
- Complete manufacturing technique management, and quality management.
- Electrode will be calibrated, tested, packed one by one.

## 1. 2 Applications

This series is widely used for the water treatment control and monitoring of water treatment (high salt content), concentrated solution, recirculating cooling water and etc.

## 1. 3 Products classification

Model	Power supply	Frequency(Hz)	Current loop modes	Constant selection	Display
CCT-3300E	DC 24V	-----	Instrument/Transmitter	0.1-1.0	Three digits and a half
CCT-3310E	AC 110V	50/60	Instrument/Transmitter	0.1-1.0	Three digits and a half
CCT-3320	AC 220V	50/60	Instrument/Transmitter	0.1-1.0	Three digits and a half
CCT-3320E	AC 220V	50/60	Instrument/Transmitter	0.1-1.0	Three digits and a half
CCT-3320T	AC 220V	50/60	Instrument/Transmitter	0.1-1.0	Three digits and a half

Note: The model with E is the EMC enhancement type.

CCT-3320T(Conductivity Monitor) without any control outputs.

## 1. 4 Notices of product installation

- i. Please choose CCT-3300E (power supply 24V DC) if the onsite with damp environment or systems with 24V power supply.
- ii. If the onsite voltage is unstable or the site is far away from the power station, please use wide range AC/DC voltage-stabilizing type DC 24V power supply, please choose CCT-3300E.
- iii. If the measurement value unstable caused by using converter system, electronic device for water treatment, UV light electronic ballast device, power supply pollution, please choose CCT-3320E
- iv. Under the small power generation device which the power unstable, or far away from the power supply, please use wide range AC/DC voltage-stabilizing type DC 24V power supply, please choose CCT-3300E
- v. UV does harm to the LCD display screen, so please do not place the meter under sunshine.

## 1. 5 Main technical feature

Name of product		CCT-3300 series of conductivity/TDS Controller			
Display		LCD display			
Auxiliary electrode Constant		0.10 cm <sup>-1</sup>	1.000 cm <sup>-1</sup>	5.000 cm <sup>-1</sup>	10.0 cm <sup>-1</sup>
Electrode coefficient range		0.070- 0.130 cm <sup>-1</sup>	0.70 -1.30 cm <sup>-1</sup>	3.50 -6.50 cm <sup>-1</sup>	7.00 -13.0 cm <sup>-1</sup>
Auxiliary electrode accuracy measurement range		0.5~199.9μS/cm	1.0~1999μS/cm	0.05~9.99mS/cm	0.5~19.99mS/cm
Measurement range	conductivity	0.5μS/cm ~ 19.99mS/cm			
	TDS	0.25ppm~ 9.99 ppt			
	temperature	0.0~50.0℃			
Resolution	conductivity	0.01μS/cm			
	TDS	0.01ppm			
	temperature	0.1℃			
Accuracy	conductivity	1.5level			
	TDS	1.5level			
	temperature	±0.8℃			
Temperature compensation		NTC10K temperature component			
Working Environment		Temp.0~50℃ Relative Humidity: ≤80%RH			
Transmitting output (4~20mA)		isolated/transferable/reversible /transmitter mode/meter mode			
		Loop resistance 0--400Ω accuracy: ±0.1mA			
Control output	Output port	double contact relay output (ON/OFF)			
	load capacity	AC 220V/AC110V/DC24V 3A Max			
Power consumption		<2.5W			
Power supply		CCT-3300E	CCT-3310E	CCT-3320/CCT-3320E	CCT-3320T
		DC 24V ±4V	AC 110V ±10%	AC 220V ±10%	AC 220V ±10%
Frequency (Hz)		-----	-----	50/60	50/60
Installation		Panel mounted ,fast installation clamp			
Dimension		48mm×96mm×80mm(H×W×D)			
Slot dimension		44mm×92mm(H×W)			
Weight		0.27kg			

## II. Outline Dimension and Rear Terminals

### 2. 1 Outline dimension

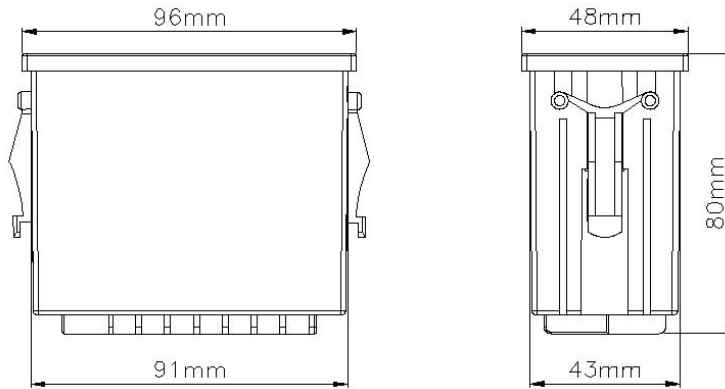

### 2. 2 Rear terminals



**CCT-3300E**



**CCT-3310E**





### CCT-3320/CCT-3320E/CCT-3320T

Note:CCT-3320T RELAY terminal is blank, without any connection.

## 2. 3 Wire connection

<b>W</b>	Connect white wire of electrode(WHITE)
<b>G/B</b>	Connect green wire of electrode(GREEN)
<b>Y</b>	Connect yellow wire of electrode (YELLOW)
<b>R</b>	Connect red wire of electrode(RED)
<b>I+ I-</b>	Under instrument mode, power supplied by meter
<b>T+ T-</b>	Under transmitter mode , power supplied by conditioning module
<b>RELAY</b>	relay contact (ON/OFF contact)
<b>24V(A)/24V (B)</b>	DC power supply
<b>0V/ 110V</b>	Power supply AC 110V
<b>0V/ 220V</b>	Power supply AC 220V
	Protective terminal of EMC ground connection (Earth)
<b>NC</b>	Empty terminal (no wire connection in-side)

### III. Electrical Connection

#### 3. 1 mA wire connection diagram

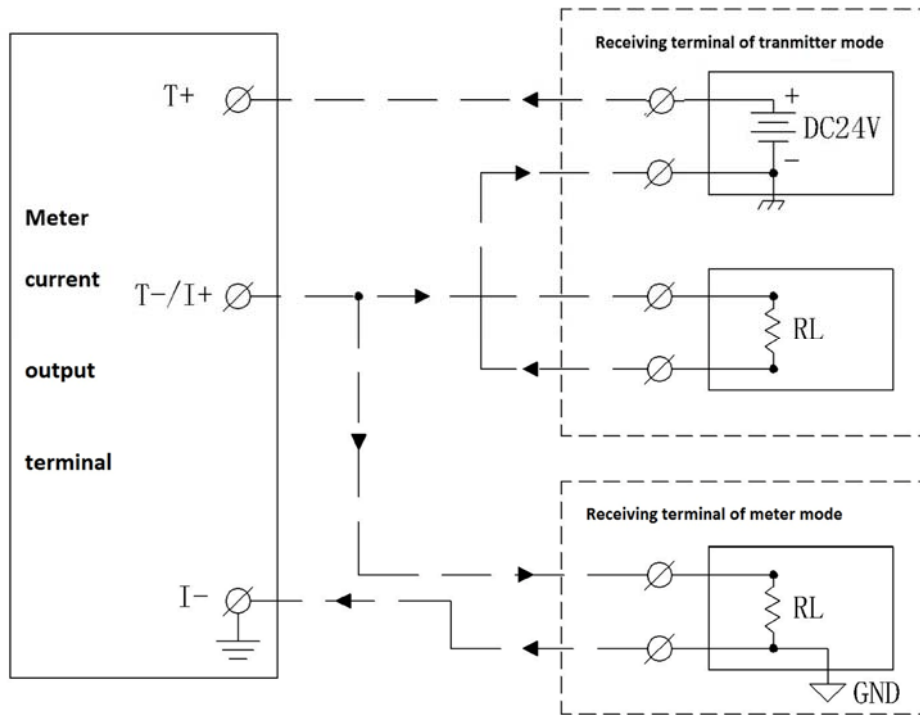

Connection diagram of 4~20mA signal under different modes

### 3. 2 Electrical connection

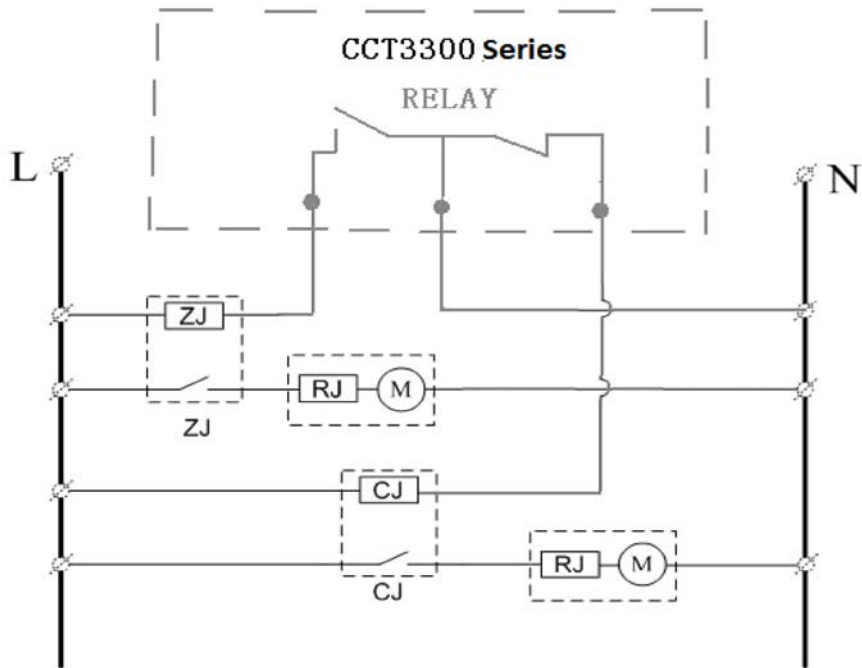

Connection diagram of ON/OFF relay

### 3. 3 High limit and window control.

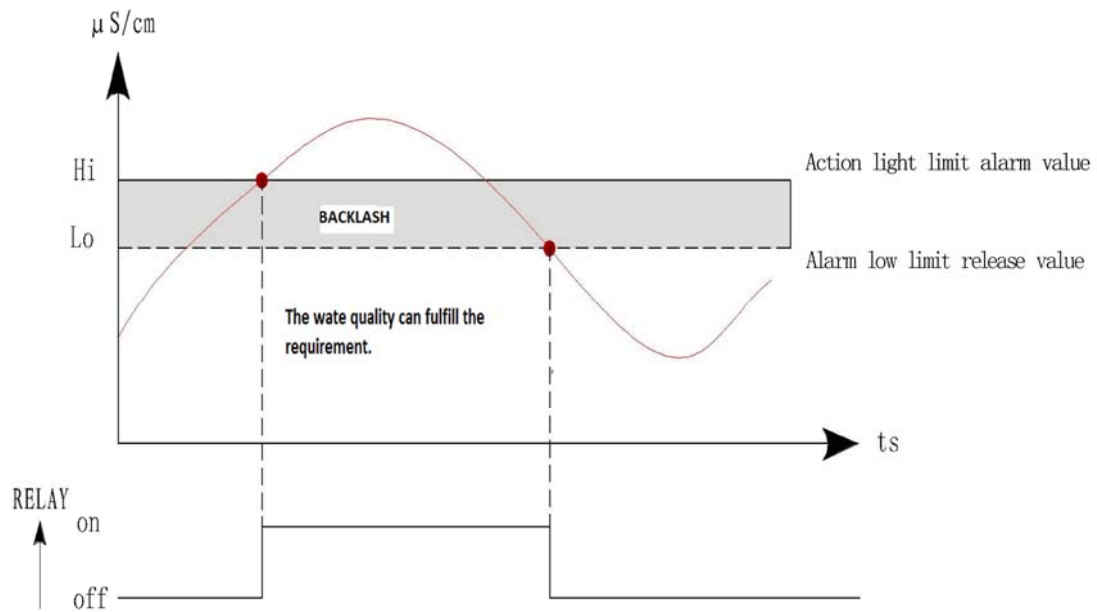

### The water quality is limited within HIGH limit

If the meter is used for pharmaceutical industry, food, drink, water purification and etc, when the water quality is limited at **HIGH limit**, the solenoid valve will switch the water flow direction to make sure the water purity. When the water quality at **LOW limit**, the meter will back to normal operation. The space between HIGH and LOW is backlash. Backlash will avoid the solenoid valve shock.

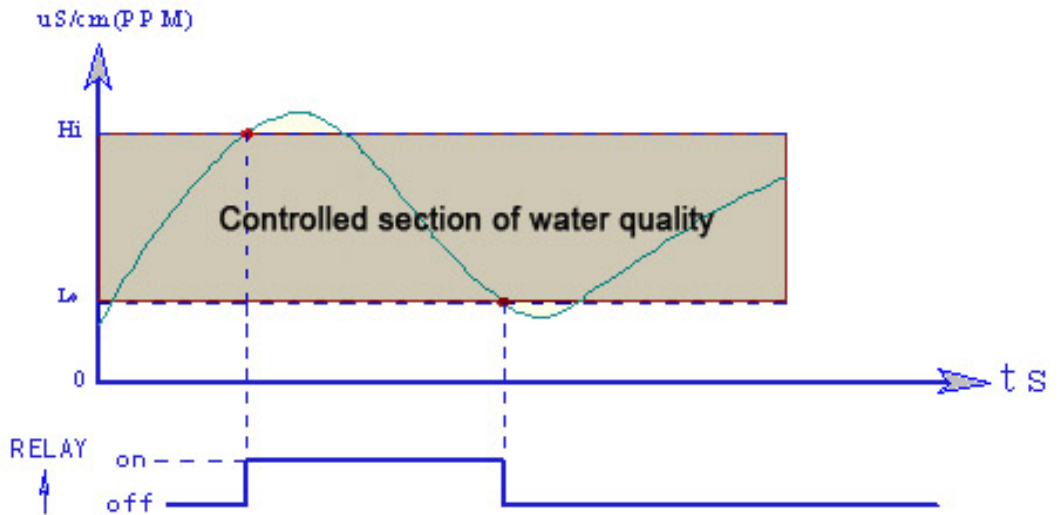

When the meter is used for circulating cooling water, cooling liquid, cleaning solution, when the water quality is so bad that at HIGH, the meter will discharge the water. When the water quality is better at LOW, discharge stopped.

## IV. Introduction of front panel and key functions

### 4. 1 Front panel and main menu display



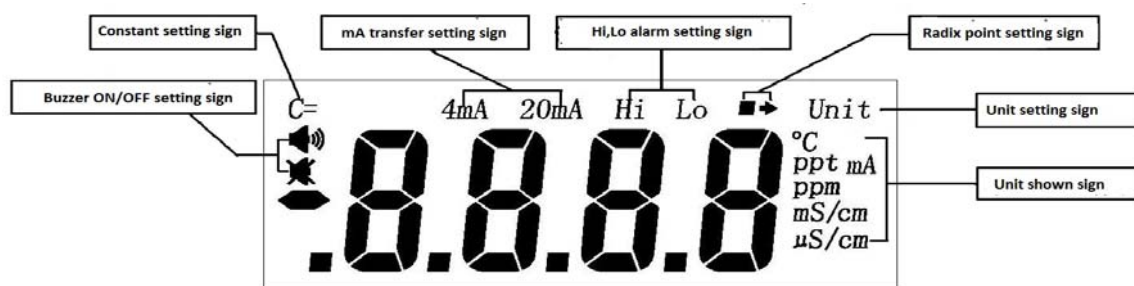

#### 4. 2 Key board functions Introduction

Key sign	Name	Function
»	select key	1.parameter setting to select thousand,hundred,ten and unit in circulate 2.radix point position setting 3.Measurement switch to display conductivity/TDS
⌆	Add key	1. Adjust the value under setting status. 2. Check the temperature/mA/ conductivity (TDS) reading under measurement status.
↻	Enter key	1.Enter parameter setting under main menu 2.Save the parameters and enter next menu

#### V. Introduction of Operation Menu

Under main measuring menu, pressing “↻” for three seconds and enter setting menu automatically

order Setting	Menu name	Introduction for function
1	Electrode constant setting	The sign “C=”blink on display screen, operating selectkey and add key to input the needed electrodeconstant value, pressing enter key to save andenter next parameter setting.
2	radix point setting	The radix point sign on display screen blink, press select key to set radix point position; press enter key to save and enter next parameter setting.
3	Measurement unit setting	The sign “Unit” blink on display screen, press add key to select measurement unit (ppm , ppt, µS/cm or mS/cm), press enter key to save and enter next parameter setting.
4	4mA transfer v setting	The sign “ 4mA”blink on display screen, press select key and add key to input the 4mA transferable value and press enter key to save and set the radix point ( the same procedures as electrode constant setting ),press enter key to save and enter next parameter setting.
5	20mA transfer setting	The sign “ 20mA”blink, setting the data according to 20mA and press enter key to set the radix transferable value, press enter key enter the next parameter setting
6	Alarm hi-limit setting	the sign “Hi” and 🔊 blink, press select key and add key to input the needed hi-limit value; press enter key to save, and then set the radix point bits, press enter key to save and enter the next parameter setting.

7	Alarm release setting	The sign  and “Lo” blink, other setting is the same as the above, pressing enter key to save and enter the next parameter setting.
8	Alarm switch	Obligate function ,No at present

Note:CCT3320T Setting Menu don't contain 6、7、8、 item.

## VI. Introduction for Electrode Installation

### 6. 1 Selection for electrode constant

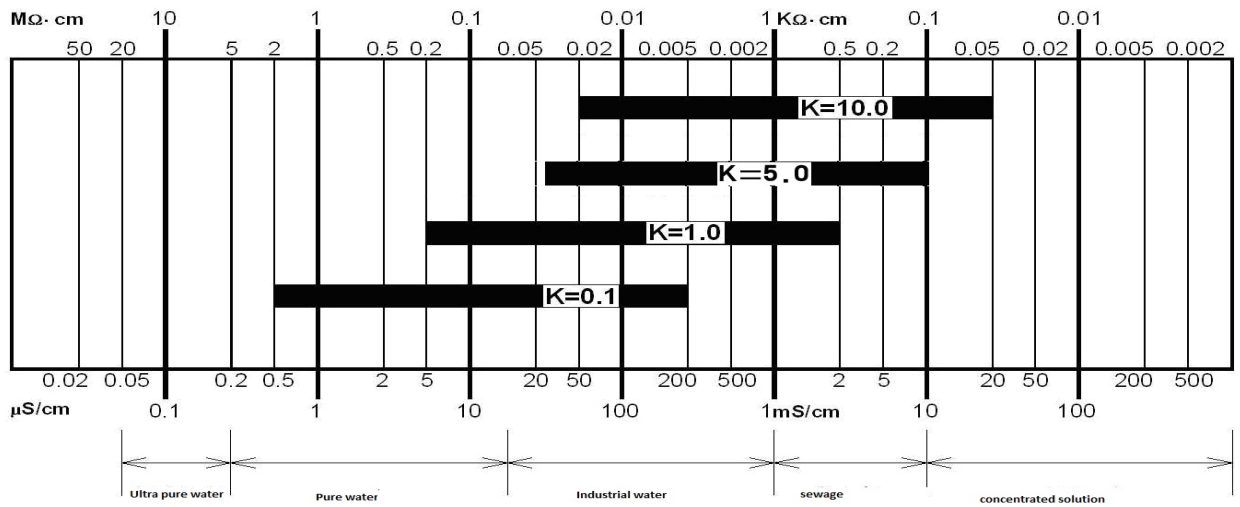

The measurement range depends on the electrode constant, so please choose the suitable electrode constant for your applications.

### 6. 2 Outline dimension of the electrode

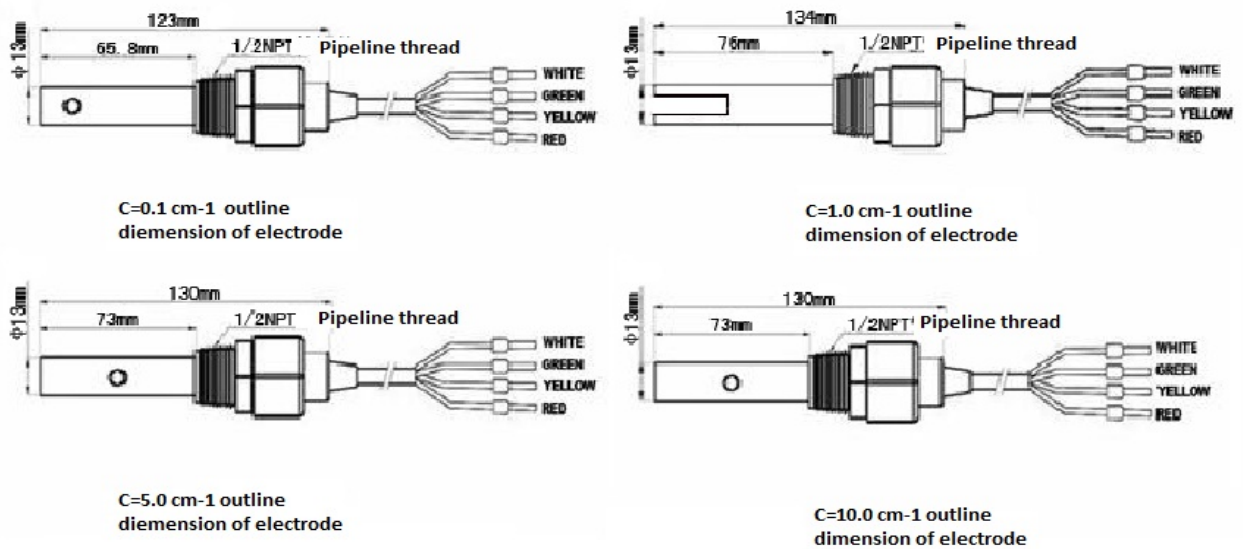

### Outline dimension of the electrode

### 6. 3 Installation method

Please follow the correct installation method to install the electrode strictly. The incorrect installation will cause the reading error.

1) **Picture 1a** the fitting is too long and the stretched parts is too short, which will lead to the dead space in electrode and incorrect measurement. please follow the picture **1b (FLOW=stretch into flow direction deeply)**.

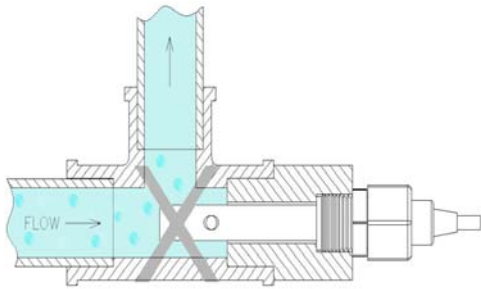

Installation 1a

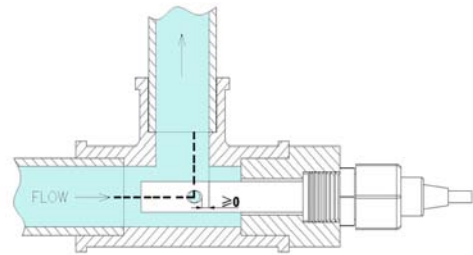

installation 1b

2) **Picture 2a**, the installation mode will lead to air space and incorrect measurement and instability. Please follow the picture **2b**

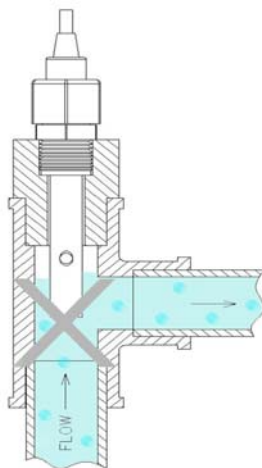

Installation 2a

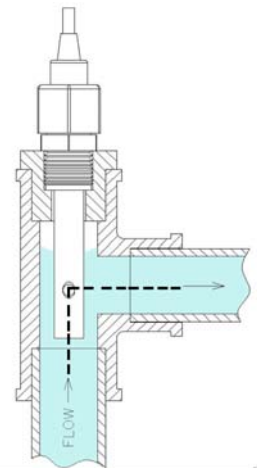

installation 2b

3) Picture 3 , there will be air space inside the pipeline, the air will cause incorrect reading.

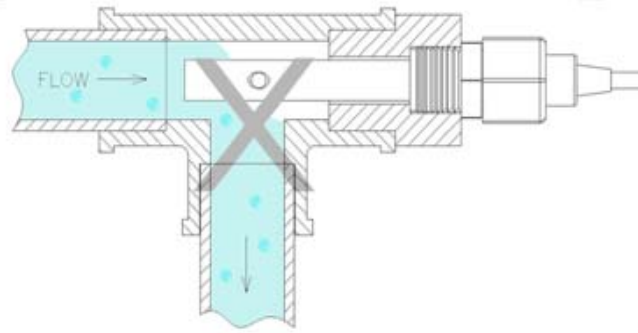

4) Picture 4a, the below installation will cause incorrect reading ,because the water can not through the measuring hole of the electrode.

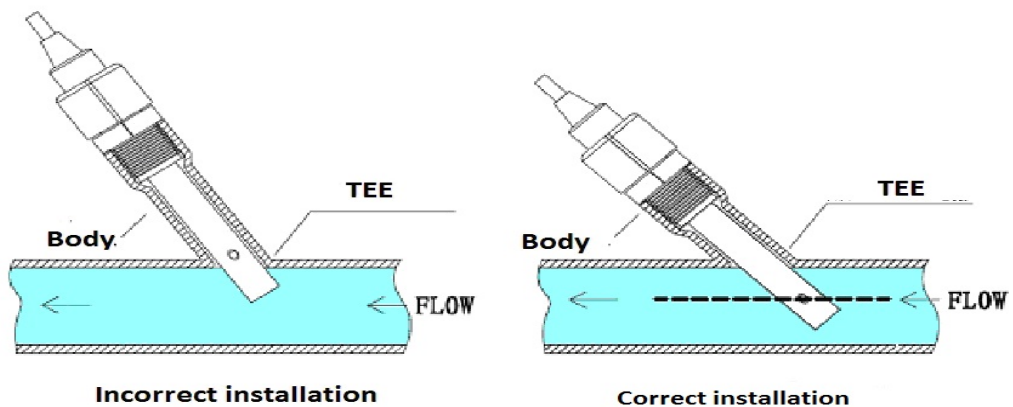

## 6. 4 Installation and maintenance

Notes:

- (1) The electrode should be installed in a place in the pipeline where the stream is steady and air bubbles are hard to generate.
- (2) No matter the conductance cell is horizontally or vertically installed, it should be deeply inserted into the moving water.
- (3) The conductivity signal is weak electronic signal and its collecting cable should be separately installed. When threading cable joint or connecting terminal board is used, to avoid wetting interference or breakdown of measurement unit circuit, they should not be connected to the same group of cable joint or terminal board with the power line or control line.
- (4) When the measurement cable needs to be lengthened, it's recommended to make an



agreement with the factory before placing an order.

- (5) Please keep the measuring part of electrode clean, and do not directly contact the surface by hands or contact with the oil stain objects
- (6) Electrode is a kind of precision components, so please do not change any part of the electrode. The accuracy will be incorrect if the electrode was destroyed by the strong acid, strong alkali, scrape from machine and etc.
- (7) The meter is made by precision integrated circuit and electronic components, so it needs to place in case or dry environment.
- (8) In order to guarantee the safety operation, pls checking after installation then switch on.

## VII. Failure Judgment for Meter and Electrode

When the reading is incorrect or unstable, please check the meter and electrode.

- a. Distinguish the failure source which comes from meter or electrode

Firstly, remove the white wire from the wire terminal and check the conductivity reading, if the reading is 0 and stable, the meter is good. The problem can be initially identified from the electrode installation.

- b. Sensor installation question failure judgment.

Remove the electrode from the fittings, and then use the electrode to test the water quality (user already know the conductivity reading of the water before test) . If the reading is correct, so the installation is correct. If the reading with error, so the electrode failure.

- C. Meter mode or transmitter mode of 4~20mA judgment.

Before the judgment please makes sure there is no wire connection on the terminal.

mA mode	Output terminal	Voltage of terminal	Voltage of cable
Meter mode	I+/I-	>12V DC	no
Transmitter mode	T+/T-	no	DC24V

### General fault inspection and trouble shooting:

Symptom	Possible factor	Trouble shooting methods
1. No reading	A. No power supply connection B. Instrument fault	A. Check to the wire connection of power supply B. Maintained by professional.
2. Unstable reading	A. Wire connection of CELL incorrect Incorrect electrode installation B. Unstable flow speed D. So fast flow speed in some part	A. Check the wire connection of manual. B. Adjust the pipe or select another measurement point C. Use the steady water supply to eliminate the meter factor.

3.Serious error of reading	A. Incorrect constant Setting B. The electrode constant is changed Incorrect electrode installation	A. Reset the electrode constant B. Change the electrode by new one. C. Install the electrode at where the flow's speed is suitable. D. Put the electrode deeply into the flowing water.
4.different mA reading between sender and receiver	A. Reviver transfer error B. Not up to 20mA C. Incorrect setting on sending D. mA transfer error	A. Set the transfer setting again B. Loop resistance is too large, enlarge the cable. C. Set the corresponding of mA and reading again. D. Use the <b>ammeter to check the current.</b>

### VIII. Complete Set of Products

Conductivity /TDS transmitting controller installation clamp)	one piece (with a pair of fast
Electrode	one piece (5m cable length)
Operation menu	one piece

### IX. Ordering Directory

CCT-3300 series including 4 models, please check the below items to choose the suitable power supply, material, fixed method for your applications

Model No.	Power supply	Electrode constant	Connection	Electrode material
CCT-3300E	DC 24V	0.10 cm <sup>-1</sup>	<input type="checkbox"/> Thread <input type="checkbox"/> ferrule	316L
CCT-3310E	AC 110V	1.00 cm <sup>-1</sup>		316L plastic
CCT-3320	AC 220V	5.00 cm <sup>-1</sup>		Graphite
CCT-3320E	AC 220V	10.00 cm <sup>-1</sup>		Graphite
CCT-3320T	AC 220V	10.00 cm <sup>-1</sup>		Graphite

**NOTE :**

**Cable length: 1m, 5m, 10m, 20m (please indicate another especial length before placing an order).**

**The model with E is EMC enhancement type  
CCT-3320T(Conductivity Monitor) without any control outputs.**

\*Without the influence on the operation, any small change or improvement on the products by the manufacturer will not be notified separately. Please make the object as the standard.

